

OUTBOARD MOTOR NOMENCLATURE

Sometimes the words "right" and "left" are very confusing when referring to the sides of an outboard motor. Therefore, the sides are referred to as STARBOARD or PORT sides. STARBOARD means on the right hand while facing the bow (FRONT) of the boat; PORT means left hand. See Figures 1-1 and 1-2.

Service required for outboard motors is generally one of three kinds . . .

1. NORMAL CARE AND MAINTENANCE, which includes putting a new motor into operation, storing motor, lubrication, and care under special operating conditions such as salt water and cold weather.

2. OPERATING MALFUNCTIONS due to improper motor mounting, propeller condition or

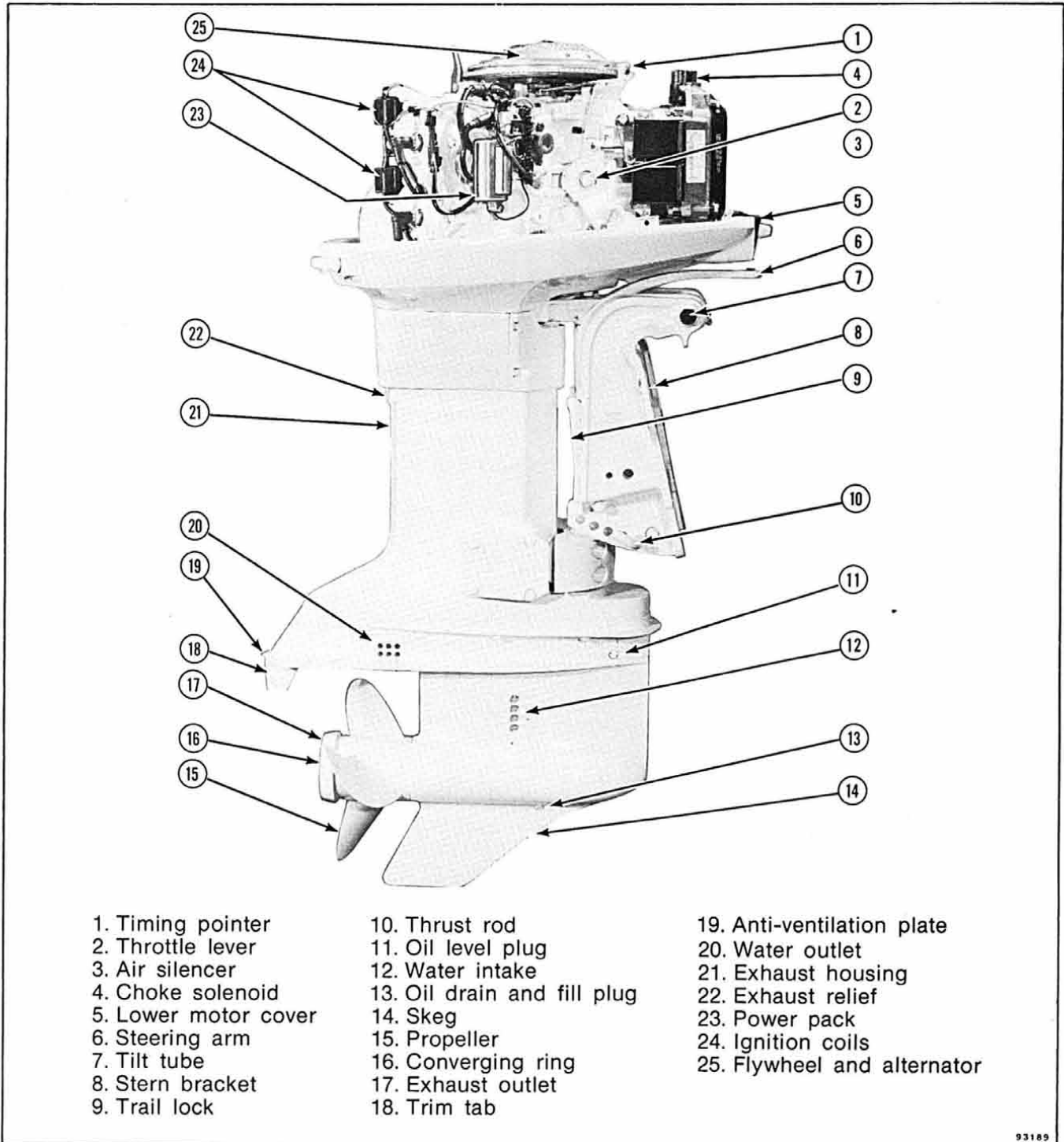

Figure 1-1. Starboard View - 140 HP